



CUSTOM POWER DESIGN

ELECTRONICS CONSULTANTS PROVIDING CUSTOM DESIGN, DEVELOPMENT, TEST & SUPPORT



Tel: + 44 (0)118 983 1222

A DIVISION OF SMET LTD

www.custompsdesign.com

Unit 1, The Forge, Reading Road, Burghfield Common, Reading, RG7 3BL.

custom@custompsdesign.com

INFORMATION SHEET AND USER GUIDE FOR

REMOTE POWER SYSTEMS FOR SIGNAL AND DATA CABLING.

ALLOWS REMOTE POWERING OF MAINS EQUIPMENT OVER NETWORKS AND TWISTED PAIRS.

MODEL	OUTPUT	O/P CONNECTOR	MODEL	OUTPUT	O/P CONNECTOR
SM4500	230V 'Mains DC'*	3 PIN KETTLE TYPE	SM4504	230V AC	3 PIN KETTLE TYPE
SM4501	230V 'Mains DC'*	2 PIN CASSETTE	SM4505	230V AC	2 PIN CASSETTE
SM4502	115V 'Mains DC'*	3 PIN KETTLE TYPE	SM4506	115V AC	3 PIN KETTLE TYPE
SM4503	115V 'Mains DC'*	2 PIN CASSETTE	SM4507	115V AC	2 PIN CASSETTE

*'Mains DC' refers to rectified mains, very efficient when used with switching PSU units (most IT equipment).

GENERAL: These Remote Power Systems are for use wherever equipment needs up to 20W (15W AC versions) of Mains power at the end of a network or signal cable. An AC mains outlet would be needed close to every installation, which can be costly and difficult to install, especially in industrial environments. This system feeds power at low voltage DC along the signal cable and converts it to mains level at the far end using a DC to AC inverter.

The following description applies for standard CATEGORY 5 NETWORK CABLING but may be read across to any wiring: - The remote equipment connects to the network cabling from a Host or Hub which is always powered from a local AC supply. The network connection uses FCC RJ45 style 8 pin connectors and cable. Only four wires in the 8 wire standard network cable are used for data, leaving four wires spare. These are used to feed low voltage DC power from the Master unit to an inverter Slave at the remote end. The Master is plugged into the same mains as the Host. Models are available that generate various regulated DC voltages at the remote cable end, see our SM4490 series.

KIT DESCRIPTION: The Remote Power System kit (1 per item of equipment) consists of two parts: -

- i) The Master unit (SM450xM) is a mains power unit connected between the host network connection and the network cable, allowing connection of low voltage (48V) DC to the four spare network wires arranged as two pairs. FCC RJ45 type inlet and outlet sockets are provided as well as a 2 metre long mains cord for connection to an AC mains outlet
Size is 110mm x 70mm x 64mm.
- ii) The Slave unit (SM450xS) is a cable adapter with an inverter inside. The Slave is connected between the long network cable and the normal network connection to the remote equipment. It has FCC RJ45 sockets for the network cable to plug into, and for onward connection to the equipment. There is also an IEC power connector on a flying lead which plugs into the mains input socket on the remote equipment.
Size is 112mm x 115mm x 33mm.

CABLING: In addition to the AC supply for the Master, three direct data cables are required: -

- 1) A short cable from the hub or host to socket PT1 on the Master unit (SM450xM). A standard direct patch cable is suitable. WARNING: Do not plug the host into socket PT2 even for a second, as the host may be damaged.
- 2) A full network cable between socket PT2 on the Master and socket PT2 on the Slave. All 8 wires must be connected. Note that pins (wires) 4, 5, 7 and 8 carry the DC power from Master to Slave.
- 3) A short cable between socket PT1 on the Slave unit (SM450xS) and the Remote Equipment. A standard direct patch cable is suitable.

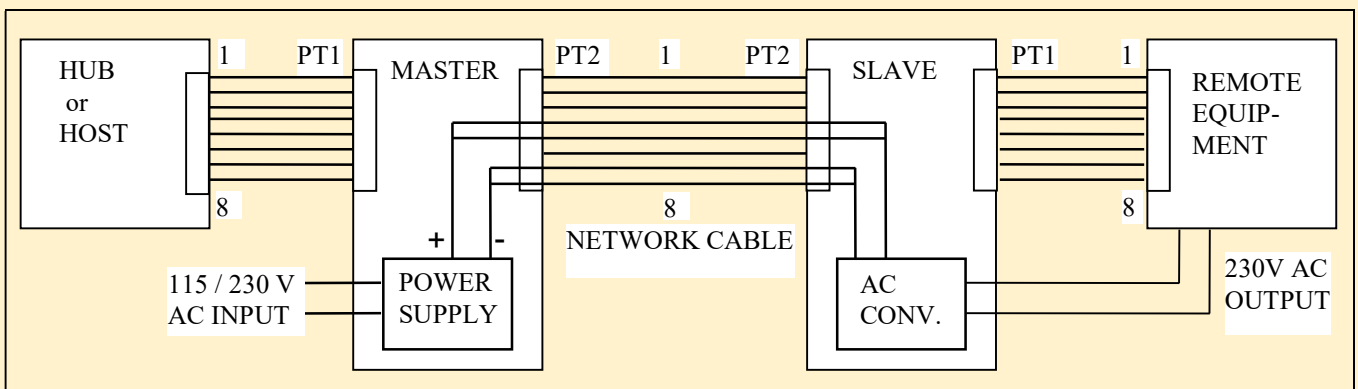

See the SM4490 series for Remote Power Systems that generate various DC voltages at the remote end.

We manufacture a wide range of DC-DC converters, DC-AC (mains) inverters and many other power systems.

We specialise in the custom design of Hydrogen Stack converters up to 10KW.

Made in the UK.

We reserve the right to change the specification without notice.

Document 4500-993