



# CUSTOM POWER DESIGN

ELECTRONICS CONSULTANTS PROVIDING CUSTOM DESIGN, DEVELOPMENT, TEST & SUPPORT



Tel: + 44 (0)118 983 1222

A DIVISION OF SMET LTD

www.custompsdesign.com

Unit 1, The Forge, Reading Road, Burghfield Common, Reading, RG7 3BL.

custom@custompsdesign.com

## INFORMATION SHEET AND USER GUIDE FOR INTERMEC ACCESS POINT 2100 NETWORK POWER KIT

(See Data sheet 3895-993 for Access Point AP110)

Office Environment: Model SM3897: 220/230V AC. Model SM3898: 110/115V AC.  
IP65 Environment: Model SM3899: 220/230V AC. Model SM3894: 110/115V AC.

**GENERAL:** The latest Intermec Access Points are fitted with a small internal AC mains switched mode power supply. A mains AC power outlet is therefore needed close to every Access Point. Safe AC outlets can be very costly and difficult to install in required locations especially in industrial environments.

The Access Point connects to the network via a Hub which is always powered from a local AC supply. The network connection uses FCC RJ45 style 8 pin connectors and cable. Only four wires in the 8 wire standard network cable are used for data, leaving four wires spare. These can be used to carry safe low voltage DC power to the Access Point for local conversion to mains level voltage for running the Access Point. The low voltage Master (see below) may be plugged into the same mains outlet as the Hub. Note this system is not suitable if a heater is fitted to the Access Point.

**KIT DESCRIPTION:** The network power system kit (1 per Access Point) consists of two parts: -

i) The Master unit (SM389xM) is a mains power unit connected between the normal network connection to the Hub and the network cable, allowing connection of low voltage (48V) DC to the four spare network wires arranged as two pairs. FCC RJ45 type inlet and outlet sockets are provided as well as a 2 metre long mains cord for connection to an AC outlet. Size is 110mm x 70mm x 64mm.

ii) The Slave unit (SM389xS) is a cable adapter with a 48V to mains converter inside. The Slave is connected between the long network cable and the normal network connection to the Access Point. It has FCC RJ45 sockets for the network cable to plug into, and for connection to the Access Point. There is also an IEC power connector on a flying lead which plugs into the AC power input socket on the Access point.

**CABLING:** In addition to the AC supply to the Master, three direct data cables are required: -

- 1) A short cable from the hub or host to socket PT1 on the Master unit (SM389xM). A standard direct patch cable is suitable. WARNING: Do not plug the hub into socket PT2 even for a second, as the hub may be damaged.
- 2) A network cable between socket PT2 on the Master and socket PT2 on the Slave. All 8 wires must be connected. Note that pins (wires) 4, 5, 7 and 8 carry the DC power from Master to Slave.
- 3) A short cable between socket PT1 on the Slave unit (SM389xS) and the Access Point. A standard direct patch cable is suitable.

Each cable should have an RJ45 plug each end. Pin 1 is connected to pin 1, pin 2 to pin 2, pin 3 to pin 3 etc. Pins 1 and 2 should use a twisted pair as should pins 3 and 6. Typical standard connection is: -

Pin 1 orange/white	Pin 5 blue/white
Pin 2 orange	Pin 6 green
Pin 3 green/white	Pin 7 brown/white
Pin 4 blue	Pin 8 brown.

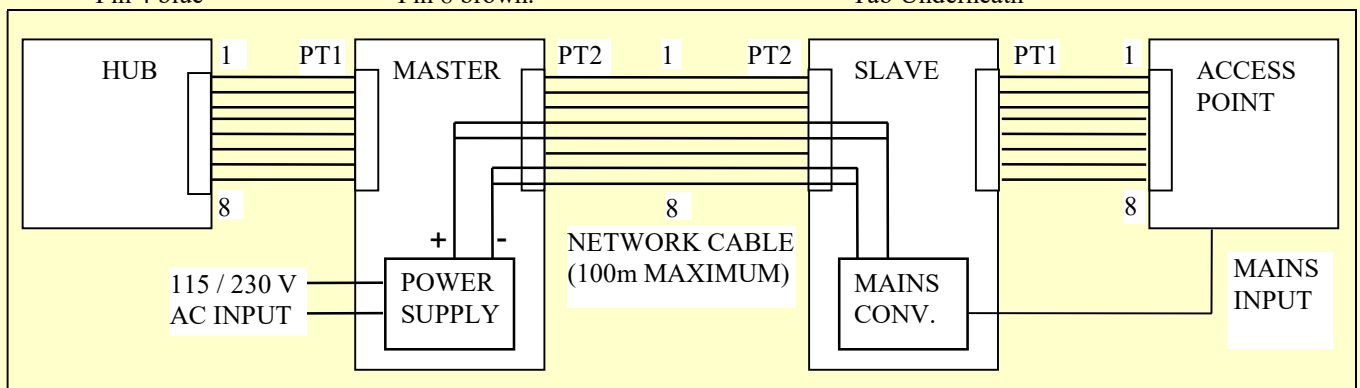
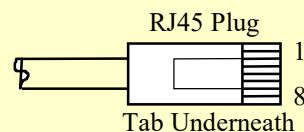

**Warning:-** Be sure that wiring is correct before powering up. Call sales for details of our 'Connect Test' to check.

Made in the UK. We reserve the right to change the specification.

Document 3897-993